

FB 3000

SOLUTION SERIES INSTRUMENTS

• Remote Terminals • Solid Waste • Transfer Stations • Sand & Gravel • Mining • Agriculture

The Ultimate Instrument for Truck Scale Applications



Take a virtual tour: WWW.FAIRBANKS.COM/FB3000

The reliability of a Fairbanks Instrument,
the convenience of a PC platform.



Catch the Wave in FB 3000 Instruments



FB 3000 Solution Series



AN ADVANCED SOLUTION TO

• Remote Terminal Applications • Solid Waste • Trans

What's so different about the FB 3000 Solution Series?

Everything. This new Fairbanks instrument was designed and engineered to revolutionize the acquisition and handling of Truck Scale data through its innovative Windows® XP software platform. Because it functions like a PC, it's easy to operate, just like a PC.

What are the advantages?

Cutting-edge functionality for real-world applications.

- Unsurpassed data storage.
- Variety of connectivity options.
- Integrated email client.
- Instant alerts for scale operators.
- Interface with analog or digital load cells.
- Intalogix® Technology.
- Automation capabilities.
- Instant data.
- Connects to existing networks.
- Interface with existing laser printers and PCs.
- Five enclosure types.
- 10.4" SVGA color display.

Optic Isolation — The power of Intalogix®

You never have to worry about power surges when an **FB 3000 Instrument with Intalogix** controls your weighing operation. Intalogix is a Fairbanks exclusive technology that acts as a shield against excessive voltage. This proven protection is achieved by optically isolating the load cells.

Intalogix also boasts incredible, high-speed, digital communications and self diagnostics. Each system load cell is analyzed 16 times per second and the FB 3000 operator receives an instant alert if any deviation in performance is detected.

Industry's Most Advanced Standard Features

- 256 MB internal memory
- 40 GB disk drive
- 85-key mini keyboard
- 2-button scroll mouse
- 10.4" full color, high resolution display
- 802.11 connectivity compatible
- Embedded Windows® XP software
- Ports: Ethernet, 4 Serial, 2 internal USB, 2 external USB, 1 PS2, 1 RS232/ 485/422, and 1 parallel

Options • Touch screen • Flash card for backup storage • Analog or Intalogix® Technology

Functions

- GTN weighing
- Load cell diagnostics with Intalogix option
- In/Out weighing
- On-board backup
- Drives up to four scales simultaneously and up to 40 load cells with Intalogix®.
- Tare storage
- Formattable tickets
- Email alerts
- Remote accessible

Virtual Tour Take the FB 3000 Virtual Tour at www.fairbanks.com/FB3000.

Phenomenal



Stainless steel enclosure.



Black finish for non-hostile environments.



Optional slim profile monitor for limitless mounting possibilities.

Aluminum enclosure



Optional Touch Screen.



Optional wall mount configuration.



85-key mini keyboard and two-button scroll mouse come as standard features with all FB 3000 models.

Features the most advanced surge protection technology in the industry.

INTALOGIX

0 Instruments



SIMPLIFY TRUCK SCALE DATA ACQUISITION

fer Stations • Sand & Gravel • Mining • Agriculture

Features

Many ports and connection possibilities.



Only scale instrument to operate on a Windows XP platform.



Remote Terminal with Card Reader? No problem! Done in 6 easy steps.



1. Scale user drives onto scale and swipes card or enters ID number.
2. User chooses "Account."
3. User selects type of "Material" being weighed.
4. User confirms weighment information or selects "Start Over" to edit.
5. Weight is taken, recorded to database, and ticket printed.
6. Translation information is available for reporting or transfer to other software applications.



Remote configuration capabilities? Fairbanks is breaking new ground, again.



The FB 3000 has a factory-loaded utility that allows remote configuration from anywhere in the world, provided there is an Ethernet connection to the instrument. Fairbanks was the first to introduce such a tool back in the '90s with Winlogix® software. Now, Fairbanks has raised the bar again, taking remote access to new heights through the FB 3000's easy-to-use, interactive interface.

Interact Software: A package to fit any user

Fairbanks' Interact Database Scale Transaction Software is a versatile truck scale data management application. It is designed for customers who need flexibility, data storage, data reporting and data networking capabilities.

Interact Inside comes standard on all Fairbanks FB 3000 Instruments. Two other versions of Interact are available. One is sure to fit your needs.

Interact Inside - Standard on all FB 3000 models
Feature-packed software for in/out weighing, stored tares, basic material tracking and basic reporting.

Interact SE - Factory option or field upgrade
Offers custom reports, table pricing, freight charges, trailer tares and an import/export utility.

Interact Professional - Factory option or field upgrade
Offers accounting features such as invoicing, payment tracking and reconciliation reports.

Call your local Fairbanks representative today to schedule a hands-on FB 3000 demonstration!

FB 3000

SOLUTION SERIES
INSTRUMENTS

DIMENSIONS

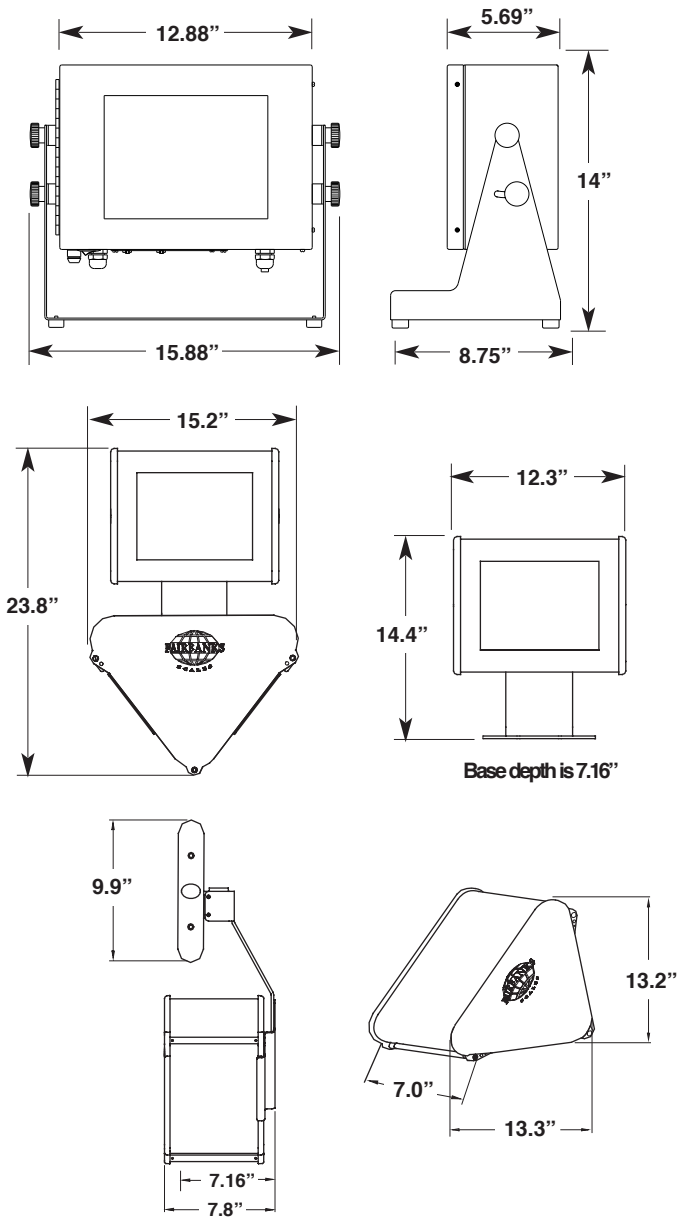

SPECIFICATIONS

Display	10.4" Color SVGA - 600 x 800 Optional touch screen
Memory	256 MB RAM (expandable)
Storage	40 GB (expandable)
SDD Interface	One 50-pin compact Flash socket; flash card is optional
Enclosure	SS NEMA 12; Painted steel NEMA 12; Anodized aluminum NEMA 12
Device Platform	XP embedded
Outputs	4 USB ports - Two external (expandable); 4 Serial ports (expandable) - Three RS-232 and one S 232/422/485 1 RJ45 port for network connection, PCI 100/10 Mbps Ethernet controller; 1 Parallel port, one bi-directional parallel port supports SPP/ECP/EPP; 1 SVGA port; 1 PS2 port, supports PC/AT keyboard PS2 mouse
HID	Mini keyboard (black), 87 key, PS2
Mouse	2 button with wheel, USB
Number of scales	Up to 4 with Intalogix Card installed; 1 with Analog Card installed (expandable)
Battery	Lithium, data retention up to 10 years
Options	Expanded Memory; Analog or Intalogix®; Touch Screen - includes electronics, hardware and factory installation, load cell interface
Accessories	Flash card; Expansion serial ports; Expansion USB ports; Wireless ethernet, Relay box; Traffic lights
Approvals	NTEP COC# 04-013A1; CWM #AM-5552C

Leasing

Convenient, affordable leasing options available through Fairlease. Ask your Fairbanks sales representative for details.

Call toll-free for the representative nearest you:

(800) 451-4107

Call between 8:00 a.m. - 5:00 p.m. CST

Corporate Offices: 821 Locust • Kansas City, MO 64106 • (816) 471-0231

Internet Address: <http://www.Fairbanks.com>



St. Johnsbury manufacturing
facility registered in
compliance with ISO 9001:2000.

