

# QuickSilver

The New Standard in Sanitary Bench Scale Design

For Ready-To-Eat, Food, Chemical  
and Pharmaceutical applications.

## Stainless Steel Bench Scales



• Quick to Weigh • Quick to Checkweigh • Quick to Clean



Visit [www.Fairbanks.com/QuickSilver](http://www.Fairbanks.com/QuickSilver)



# QuickSilver

## STAINLESS STEEL BENCH SCALES

### APPLICATIONS:

- RTE Washdown
- Gross Weighing
- Gross/Tare/Net Weighing
- Manual Batching, filling or blending with totalizing
- Over/Under Checkweighing
  - 3 Over/Under Modes:
    - (1) Sample Target & Weight Mode.
    - (2) Sample and manual entry of weight limits of acceptable range.
    - (3) Manual entry of individual setting to establish sensitivity parameters of the under, over and accept ranges.

### WHAT SETS THIS SCALE APART?

- Type 304 Stainless Steel Construction, Nema 4X Indicator enclosure.
- Conformal coated electronic circuit boards for extra protection.
- Stainless Steel Load Cell on most models.
- Pillar Offset prevents dripping, drawing or drainage of moisture into the product contact zone. Closed corners on platform cover prevent splash collection of processing materials inside the scale.
- Food contact surface treated with antimicrobial coating (optional).
- Bushings and spacers used to eliminate lap joints — facilitates quick and easy cleaning and sanitizing.
- No processing material or water collection points.
- All surfaces are visible and accessible for cleaning and sanitizing.
- Cleaning SOP included in the Operator Manual.
- Tilt adjust indicator.
- Highly Visible Blue Vacuum Fluorescent Display.
- Easy Access Calibration Switch.
- Most reliable bench scale available.



### SANITARY FEATURES:

*Joint spacers eliminate places for bacteria to hide.*

*\*AgION™ antimicrobial coating is optional for the QuickSilver weighing surface.*

*Many large openings for cleaning and draining.*

*Open corners on base eliminate places for bacteria to hide while providing easy washing and drainage.*

*500% scale overload protection means scale is resistant to damaging loads.*

### QUICK to WEIGH



### QUICK to CLEAN



### QUICK to CHECKWEIGH



### QUICK to



## SPECIFICATIONS:

Capacities (Chart on back) . . . . .	2 to 1000 lbs.	Zero . . . . .	Programmable +/-2% or 100% of scale capacity
Platform Sizes (Chart on back) . . . . .	10" x 10" to 24" x 24"; Type 304 Stainless Steel	Auto Zero Tracking . . . . .	Off, 0.6, 1 or 3 divisions
Resolution . . . . .	5,000 divisions	Center of Zero Indicator . . . . .	Active when scale is within 0.25 divisions of zero
Indicator . . . . .	Tilt adjust; Zero/Auto Tare Toggle Switch; Easy Access Calibration Switch	Output . . . . .	RS 232C Serial Output (optional); Ethernet (optional)
Display . . . . .	Highly visible, blue vacuum fluorescent, 6 character, 7 segment display with .5" tall characters	Overload . . . . .	Up to 500% of scale capacity
Filtering . . . . .	4 levels for vibration suppression	Power Requirements . . . . .	100-130 VAC, 5 W, 50-60 Hz, grounded 3 conductor AC; or 200-240 VAC, 5 W, 50-60 Hz (optional)
Controls . . . . .	Auto Tare; Gross/Net; Units; Two Position Toggle for Scrolling Tare, Zero, Auto Tare	Configuration . . . . .	Platform, Platform w/ remote indicator, Platform w/ pillar and indicator
Units . . . . .	lb, kg, oz, gm, selectable	Approvals . . . . .	NTEP COC #94-100A1; Complies with Underwriters Laboratory safety requirements for scales.

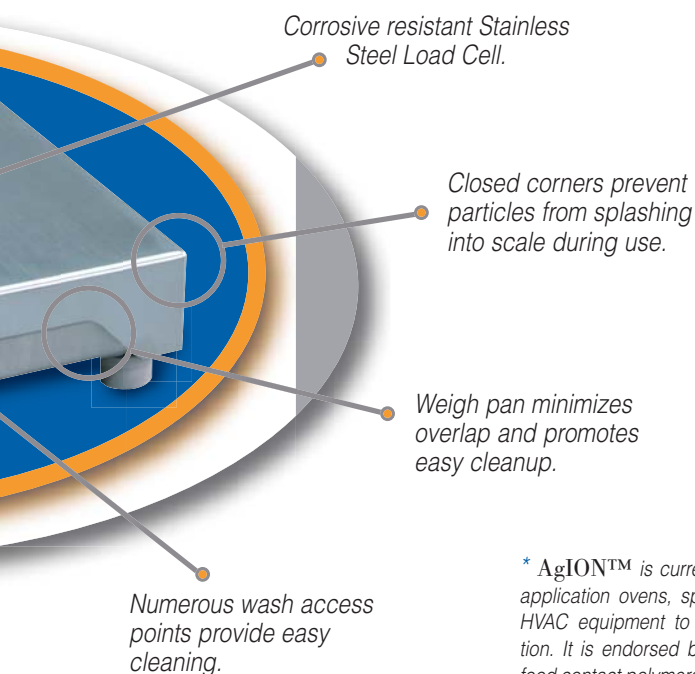

## VARIETY OF CONFIGURATIONS:



Short pillar



Five base sizes



Wall mount or free standing indicator

\* AgION™ is currently in use in food processing application ovens, sprayers, liquid dispensers and HVAC equipment to eradicate biological colonization. It is endorsed by the USDA as an additive in food contact polymers and is certified by the National Sanitation Foundation as safe and acceptable for Product Zone 1 and Food Zone 2-4 applications.

ILT

## THE NEW STANDARD IN SANITARY DESIGN

QuickSilver Bench Scales are designed to be easily cleaned and sanitized. Both the scale and its frame are completely sealed so moisture can never penetrate. All welds are continuous, which prevents processing materials and moisture from accumulating and forming colonization points for harmful bacteria like *Listeria Monocytogenes*, *Salmonella* and *E. coli*. Fairbanks Scales is the only scale manufacturer currently utilizing the American Meat Institute's Sanitary Design Checklist and assistance in new product development from individual members of the AMI's Equipment Design Task Force. The QuickSilver has been evaluated and meets or exceeds the specifications for food processing as outlined in the AMI Checklist.

These strict standards ensure that the QuickSilver is safe for use in RTE areas, as well as any other production applications.



# DEATH TO

**Listeria, E. coli, Salmonella  
and all their friends!**

# FAIRBANKS S C A L E S

## QuickSilver

### Stainless Steel Bench Scales

Optional wheelbase for the QuickSilver 24" x 24" model.

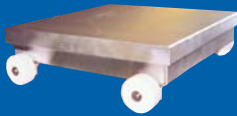

## Leasing

Convenient, affordable leasing options available through Fairlease. Ask your Fairbanks sales representative for details.

#### CAPACITIES, GRADUATION SIZES & DIMENSIONS

Capacity	Platform Size	Commercial Division Size		Non-Commercial Division Size	
		Lbs	Kg	Lbs	Kg
2 lbs	10" x 10"	—	—	.0005	.0001
6 lbs	10" x 10"	.002	.001	.001	.0005
10 lbs	10" x 10"	.002	.001	.001	.0005
25 lbs	10" x 10"	.005	.002	.002	.001
30 lbs	12" x 12"	.01	.005	.005	.002
50 lbs	12" x 12"	.01	.005	.005	.002
50 lbs	18" x 18"	.01	.005	.005	.002
100 lbs	18" x 18"	.02	.01	.01	.005
150 lbs.	18" x 18"	.05	.02	.02	.01
300 lbs.	18" x 18"	.1	.05	.05	.02
100 lbs.	18" x 24"	.02	.01	.01	.005
150 lbs.	18" x 24"	.05	.02	.02	.01
200 lbs.	18" x 24"	.05	.02	.02	.01
100 lbs.	24" x 24"	.02	.01	.01	.005
250 lbs.	24" x 24"	.05	.02	.02	.01
500 lbs.	24" x 24"	.1	.05	.05	.02
1000 lbs.	24" x 24"	.2	.1	.1	.05

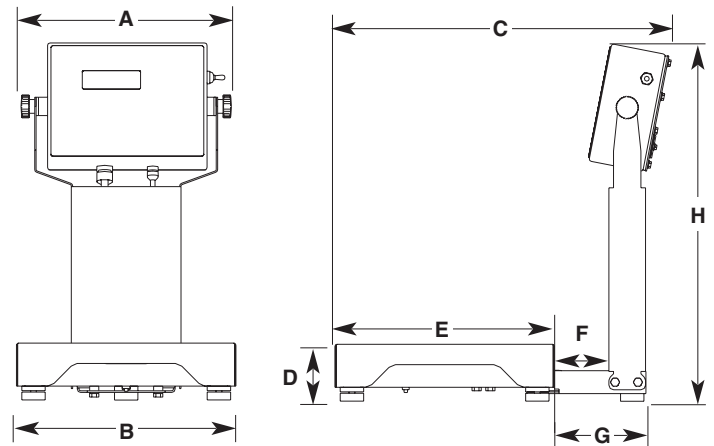

Platform Size	A	B	C	D	E	F	G	H
10" x 10"	11.43"	10"	16.37"	2.89"	10"	2.98"	4.98"	19.45"
12" x 12"	11.43"	12"	18.37"	3.10"	12"	2.98"	4.98"	10" Pillar
18" x 18"	11.43"	18"	24.37"	3.87" *	18"	2.98"	4.98"	27.45"
18" x 24"	11.43"	18"	30.15"	5.06"	24"	2.76"	4.76"	18" Pillar
24" x 24"	11.43"	24"	30.06"	5.77"	24"	2.67"	4.67"	39.45"
								30" Pillar **

\* 4.12" for 300 lb model. \*\* H dimension for the 24" x 24" with a 30" pillar is 40.47.

Call toll-free for the representative nearest you:

**(800) 451-4107**

Call between 8:00 a.m. – 5:00 p.m. CST

Corporate Offices: 821 Locust • Kansas City, MO 64106 • (816) 471-0231

Internet Address: <http://www.Fairbanks.com/QuickSilver>

Models and specifications subject to change without notice. © Fairbanks Scales Inc.



St. Johnsbury manufacturing facility registered in compliance with ISO 9001:2000.

